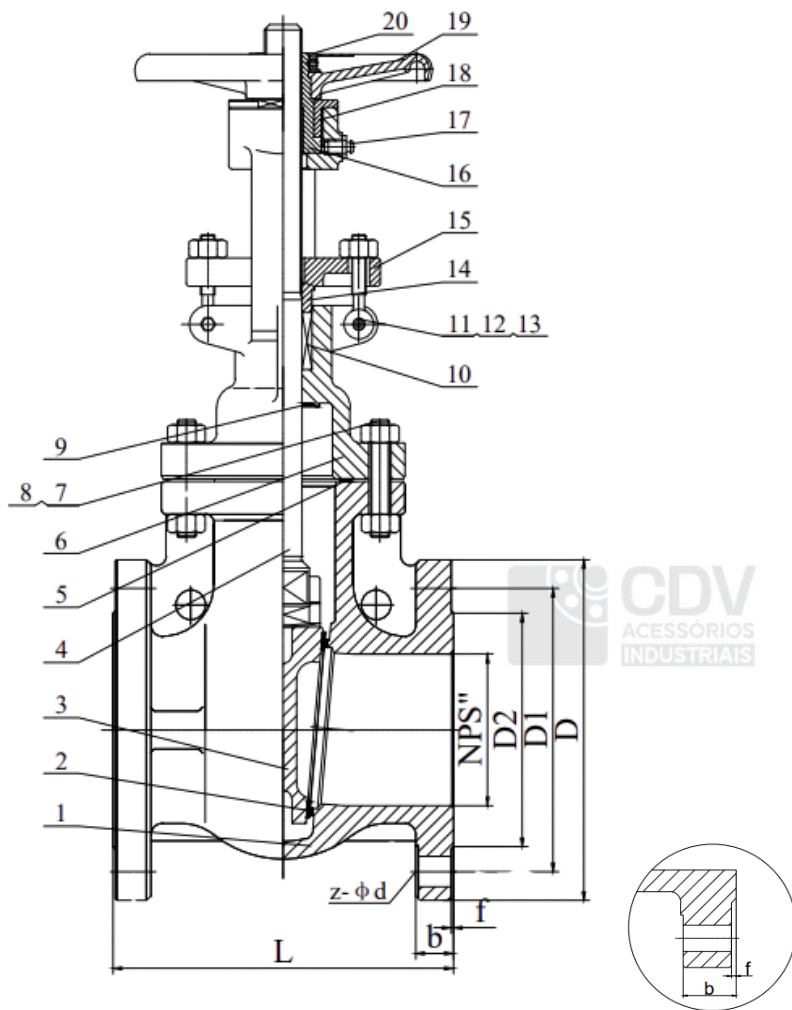

FIG. 50



NPS	L	D	D1	D2	b	z-φd	f
2"	178	ø 150	ø 120.7	ø 92.1	17.5	4-ø 19	2
2 1/2"	190	ø 180	ø 139.7	ø 104.8	18	4-ø 19	2
3"	203	ø 190	ø 152.4	ø 127	22.3	4-ø 19	2
4"	229	ø 230	ø 190.5	ø 157.2	24.3	8-ø 19	2
5"	254	ø 255	ø 215.9	ø 185.7	24.3	8-ø 22	2
6"	267	ø 280	ø 241.3	ø 215.9	25.9	8-ø 22	2
8"	292	ø 345	ø 298.5	ø 269.9	29	8-ø 22	2

Performance Specification		
Nominal Pressure	Class 150LB	Test Medium
Shell Test	(3.0MPa)	Water
Seal Test	(2.2Mpa)	
Back Seal Test	(2.2MPa)	
Air Seal Test	80Lb(0.6MPa)	Air
Suitable Temperature	-29~425°C	
Suitable Media: Water/Steam/Oil		

**Standards:**

- 1 Design and manufacture: ASME B16.34
- 2 Face to Face dimension: ASME B16.10
- 3 Flanged End: ASME B16.5 RF
- 4 Pressure temperature ratings: ASME B16.34
- 5 Pressure test: API 598

Material Table		
20	H.W.Lock nut	C.S
19	Handwheel	ASTM A 47
18	Retaining nut	C.S
17	Lubricator	Cu
16	Stem nut	ZcuA110Fe3
15	Gland	ASTM A216 WCB
14	Bushing	ASTM A 182F6a
13	Gland Nut	ASTM A 194-2H
12	Gland bolt	ASTM A 193-B7
11	Pin	C.S
10	PackKing	Graphite
9	Backseat	ASTM A216WCB+13Cr
8	Nut	ASTM A 194-2H
7	Stud	ASTM A 193-B7
6	Bonnet	ASTM A 216 WCB
5	GasKet	304S.S.Jacketed Graphite
4	Stem	ASTM A 182 F6a
3	Wedge	ASTM A 216 WCB+13Cr
2	Seat	ASTM A 216 WCB+13Cr
1	Body	ASTM A 216 WC
No.	Parts	Material
Product name: Gate valve		Classe: 150
Designer: CDV INDUSTRIAL		Type: Z41H
Date: MAR/2025		Drawing: Fig 50

FIG. 50

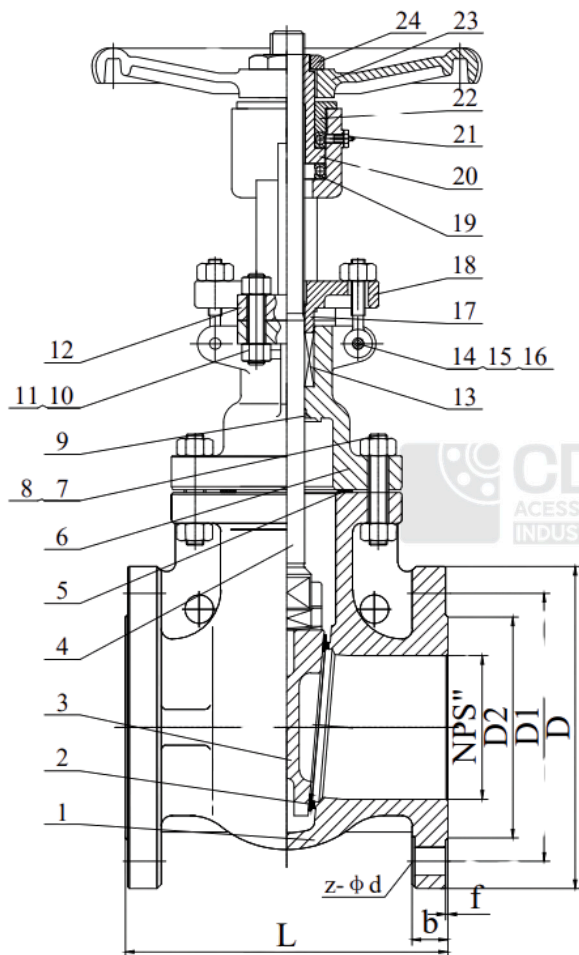

NPS	L	D	D1	D2	b	z-φd	f
10"	330	ø 405	ø 362	ø 324	31	12-ø 25	2
12"	356	ø 485	ø 432	ø 381	32.5	12-ø 25	2
14"	381	ø 535	ø 476.3	ø 412.8	35.4	12-ø 29	2
16"	406	ø 595	ø 539.8	ø 469.9	37	16-ø 29	2

Performance Specification		
Nominal Pressure	150Lb(2.0Mpa)	Test Medium
Shell Test	(3.0MPa)	Water
Seal Test	(2.2Mpa)	
Back Seal Test	(2.2MPa)	
Air Seal Test	80Lb(0.6MPa)	Air
Suitable Temperature	-29~425°C	
Suitable Media:	Water/Steam/Oil	

**Standards:**

- 1 Design and manufacture: ASME B16.34
- 2 Face to Face dimension: ASME B16.10
- 3 Flanged End: ASME B16.5 RF
- 4 Pressure temperature ratings: ASME B16.34
- 5 Pressure test: API 598

Material Table		
24	H.W.Lock nut	CS
23	Handwheel	ASTM A 47
22	Retaining nut	C.S
21	Lubricator	Cu
20	Stem nut	ZcuA110Fe3
19	Bearing	C.S
18	Gland	ASTM A216 WCB
17	Bushing	ASTM A 182F6a
16	Gland Nut	ASTM A 194-2H
15	Gland bolt	ASTM A 193-B7
14	Pin	C.S
13	PacKing	Graphite
12	Yoke	ASTM A216 WCB
11	Nut	ASTM A 194-2H
10	Stud	ASTM A 193-B7
9	Backseat	ASTM A216WCB+13Cr
8	Nut	ASTM A 194-2H
7	Stud	ASTM A 193-B7
6	Bonnet	ASTM A 216 WCB
5	GasKet	304S.S.Jacketed Graphite
4	Stem	ASTM A 182 F6a
3	Wedge	ASTM A 216 WCB+13Cr
2	Seat ring	ASTM A 216 WCB+13Cr
1	Body	ASTM A 216 WC
No.	Parts	Material

Product name:	Gate valve	Classe: 150
Designer:	CDV INDUSTRIAL	Type: Z41H
Date:	MAR/2025	Drawing: Fig 50