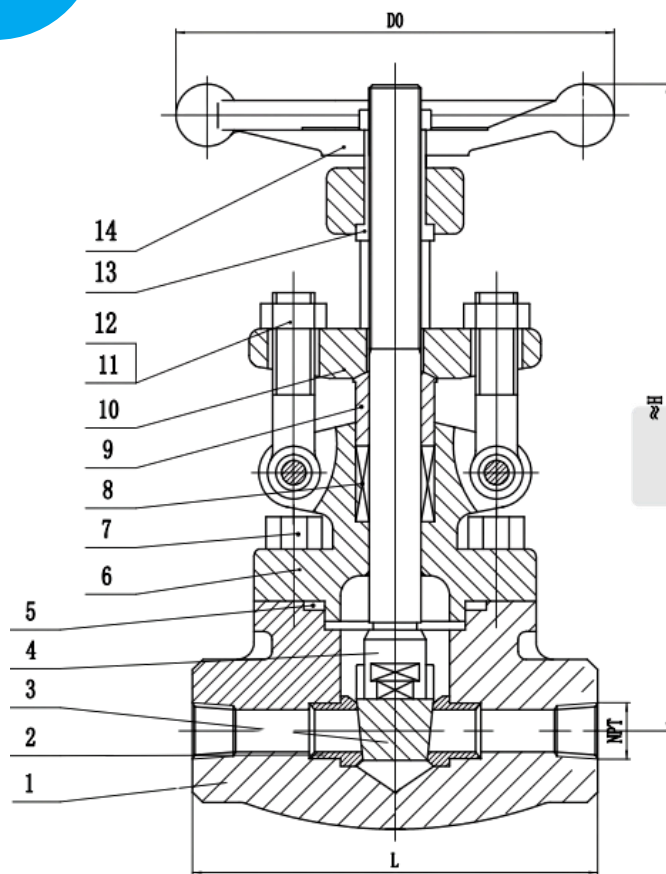

FIG.  
52



in	L	NPT	DO	≈H
1/2"	79	1/2"	100	155
3/4"	92	3/4"	100	160
1"	111	1"	125	187
1-1/4"	120	1-1/4"	160	210
1-1/2"	120	1-1/2"	160	233
2"	140	2"	180	265

Performance Specification				
<b>Nominal Pressure</b>		800LB		
<b>Pressure test</b>	Strength test	19.5	MPa	Water
	Shell test	14.3		Water
	Seal test	14.3		Water
	Low pressure seal test	0.6		Air
<b>Suitable Temperature</b>		-28~425° C		
<b>Suitable Media:</b> Water, Air and Oil etc.				

**Technical Requirements**

- 1 Design & manufacture conform to: API602
- 2 Face to Face conform to: ASME B16.10
- 3 Thread dimensions conform to ASME B1.20.1
- 4 Test & Inspect conform to API 598

Material Table		
14	Hand Wheel	KTH330-08
13	Stem Nut	Copper Alloy
12	Nut	A194 2H
11	Eye Bolt	A193 B7
10	Gland Flange	ASTM A105
9	Packing gland	S.S
8	Packing	Braided Graphite
7	Bolt	A193 B7
6	Cover	ASTM A 105
5	Gasket	304+Graphite
4	Stem	2Cr13
3	Wedge	13Cr
2	Seat	13Cr+STL
1	Body	ASTM A 105
NO.	PART NAME	MATERIAL
<b>Product name:</b> GATE VALVE NPT		<b>Class:</b> 800
<b>Designer:</b> CDV INDUSTRIAL		<b>Type:</b> Z11Y-800LB-00
<b>Date:</b> MAR/2025		<b>Drawing:</b> Fig 52

**FIG. 52**

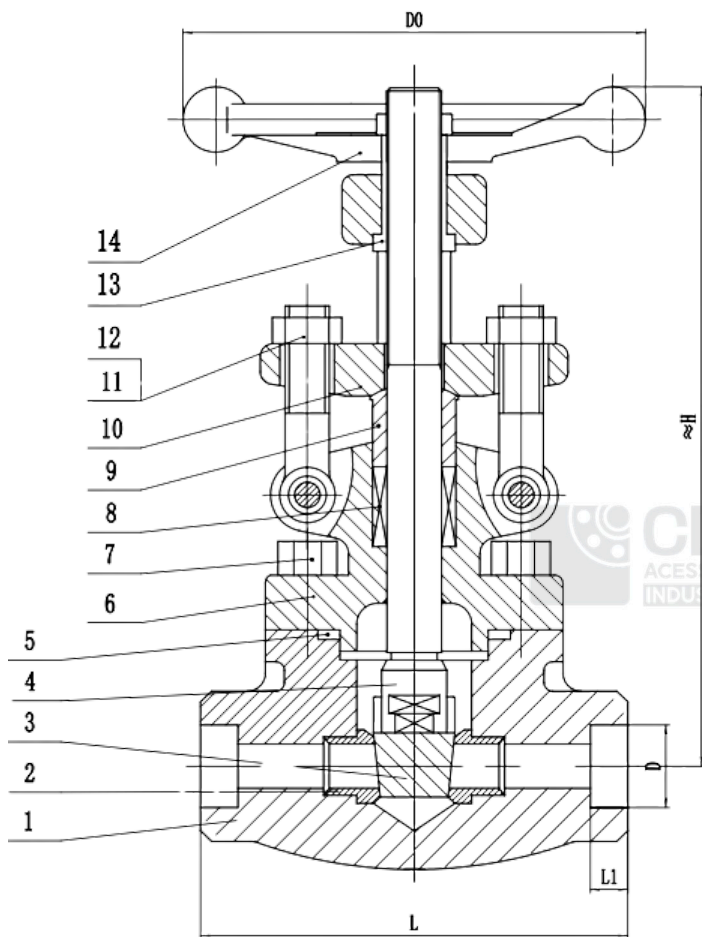

in	L	D	L1	DO	≈H
1/2"	79	21.8	9.6	100	155
3/4"	92	27.1	12.7	100	160
1"	111	33.8	12.7	125	187
1-1/4"	120	42.6	12.7	160	210
1-1/2"	120	48.7	12.7	160	233
2"	140	61.2	15.9	180	265

Performance Specification				
<b>Nominal Pressure</b>		800LB		
<b>Pressure test</b>	Strength test	19.5	MPa	Water
	Shell test	14.3		Water
	Seal test	14.3		Water
	Low pressure seal test	0.6		Air
<b>Suitable Temperature</b>		-28~425° C		
<b>Suitable Media:</b> Water, Air and Oil etc.				

**Technical Requirements**

- 1 Design & manufacture conform to: API602
- 2 Face to Face conform to: ASME B16.10
- 3 Thread dimensions conform to ASME B1.20.1
- 4 Test & Inspect conform to API 598

Material Table		
14	Hand Wheel	KTH330-08
13	Stem Nut	Copper Alloy
12	Nut	A194 2H
11	Eye Bolt	A193 B7
10	Gland Flange	ASTM A105
9	Packing gland	S.S
8	Packing	Braided Graphite
7	Bolt	A 193 B7
6	Cover	ASTM A105
5	Gasket	304+Graphite
4	Stem	2Cr13
3	Wedge	13Cr
2	Seat	13Cr+STL
1	Body	ASTM A105
<b>NO.</b>	<b>PART NAME</b>	<b>MATERIAL</b>
<b>Product name:</b> GATE VALVE SW		<b>Class:</b> 800
<b>Designer:</b> CDV INDUSTRIAL		<b>Type:</b> Z6Y-800LB-00
<b>Date:</b> MAR/2025		<b>Drawing:</b> Fig 52