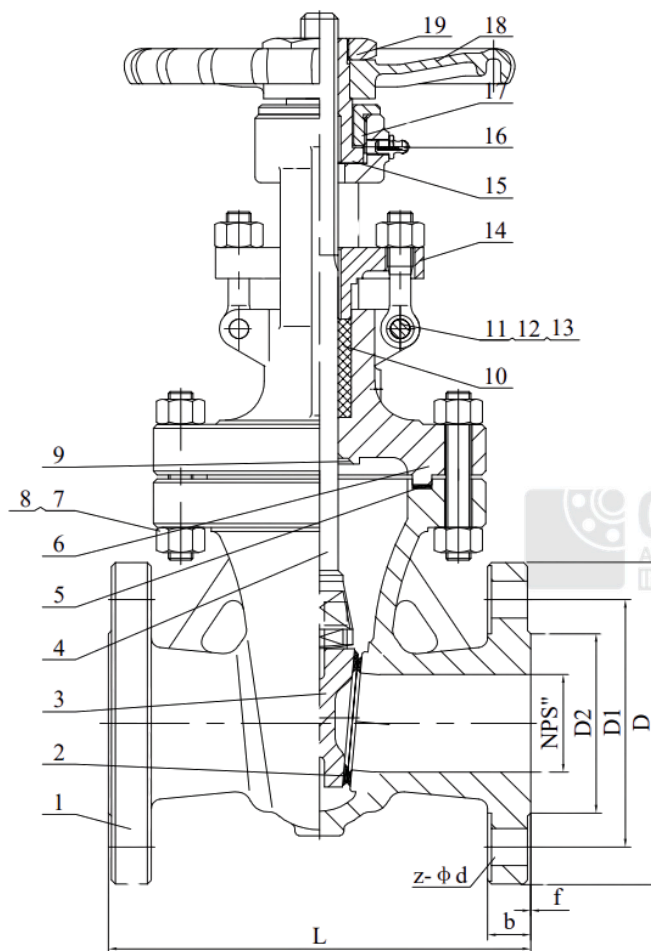

FIG.
84



NPS	L	D	D1	D2	b	z-φd	f
2"	216	φ 165	φ 127	φ 92.1	22.7	8-φ 19	2
2-1/2"	241	φ 190	φ 149.2	φ 140.8	25.9	8-φ 22.5	2
3"	282	φ 210	φ 168.3	φ 127	29	8-φ 22.5	2
4"	305	φ 255	φ 200	φ 157.2	32.2	8-φ 22.5	2
5"	381	φ 280	φ 235	φ 185.7	35.4	8-φ 22.5	2
6"	403	φ 320	φ 269.9	φ 215.9	37	12-φ 22.5	2
8"	419	φ 380	φ 330.2	φ 269.9	41.7	12-φ 22.5	2

Performance Specification		
Nominal Pressure	300Lb(5.0MPa)	Test Medium
Shell Test	(7,5MPa)	Water
Seal Test	(5,5MPa)	
Back Seal Test	(5,5MPa)	
Air Seal Test	80Lb(0.6MPa)	Air
Suitable Temperature	-29~425°C	
Suitable Media	Water/Steam/Oil	

Standards:

- 1 Design and manufacture: ASME B16.34
- 2 Face to Face dimension: ASME B16.10
- 3 Flanged End: ASME B16.5 RF
- 4 Pressure temperature ratings: ASME B16.34
- 5 Pressure test: API 598

Material Table		
19	H.W,Lock nut	C.S
18	Handwheel	ASTM A47
17	Retaining nut	C.S
16	Lubricator	Cu
15	Stem nut	ZcuA110Fe3
14	Gland	ASTM A216 WCB
13	Gland nut	ASTM A194-2H
12	Gland bolt	ASTM 193-B7
11	Pin	C.S
10	PacKing	Graphite
9	Backseat	ASTM A216+13Cr
8	Nut	ASTM A 194-2H
7	Stud	ASTM A 193-B7
6	Bonnet	ASTM A216 ECB
5	GasKed	201S.S.Jacketed Graphite
4	Stem	ASTM A 182 F6a
3	Wedge	ASTM A216 WCB+13Cr
2	Seat ring	ASTM A216 WCB+13Cr
1	Body	ASTM A216 WCB
No.	Parts	Material
Product name: Gate Valve		Classe: 300LB
Designer: CDV INDUSTRIAL		Type: Z40H
Date: MAR/2025		Drawing: Fig. 84

FIG. 84

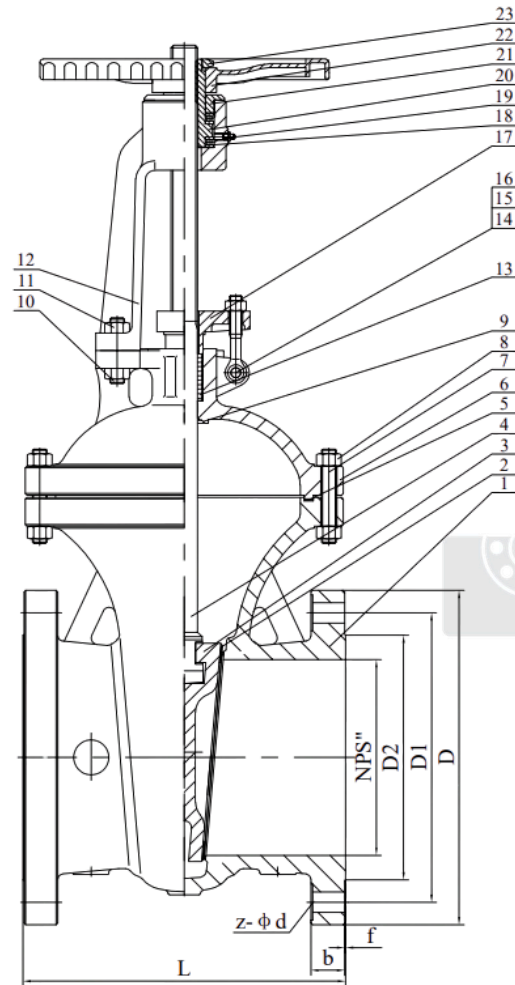

NPS	L	D	D1	D2	b	z-ø d	f
10"	457	ø 445	ø 387.4	ø 323.8	48.1	16-ø 29	2
12"	502	ø 520	ø 450.8	ø 381	51.3	16-ø 32	2
14"	762	ø 585	ø 514.4	ø 412.8	54.4	20-ø 32	2
16"	838	ø 650	ø 571.5	ø 469.9	57.6	20-ø 35	2
18"	914	ø 710	ø 628.6	ø 533.4	60.8	24-ø 35	2
20"	991	ø 775	ø 685.8	ø 584.2	64	24-ø 35	2
24"	1143	ø 915	ø 812.8	ø 692.2	70.3	24-ø 41	2

Performance Specification		
Nominal Pressure	300Lb(5.0MPa)	Test Medium
Shell Test	(7,5MPa)	Water
Seal Test	(5,5Mpa)	
Back Seal Test	(5,5Mpa)	
Air Seal Test	80Lb(0.6MPa)	Air
Suitable Temperature	-29~425°C	
Suitable Media	Water/Steam/Oil	

Standards:

- 1 Design and manufacture: ASME B16.34
- 2 Face to Face dimension: ASME B16.10
- 3 Flanged End: ASME B16.5 RF
- 4 Pressure temperature ratings: ASME B16.34
- 5 Pressure test: API 598

Material Table		
23	H.W.Lock nut	C.S
22	Handwheel	ASTM A47
21	Retaining nut	C.S
20	Stem nut	ZcuA110Fe3
19	Lubricator	Cu
18	Bearing	C.S
17	Gland	ASTM A 216 WCB
16	Gland nut	ASTM A 194-2H
15	Gland bolt	ASTM A 193-B7
14	Pin	C.S
13	PacKing	Graphite
12	Yoke	ASTM A 216 WCB
11	Nut	ASTM A 194-2H
10	Stud	ASTM A 193-B7
9	Backseat	ASTM A216+13Cr
8	Nut	ASTM A 194-2H
7	Stud	ASTM A 193-B7
6	Bonnet	ASTM A216 WCB
5	GasKet	201S.S.Jacketed Graphite
4	Stem	ASTM A 182F6a
3	Wedge	ASTM A216 WCB+13Cr
2	Seat ring	ASTM A216 WCB+13Cr
1	Body	ASTM A216 WCB
No.	Parts	Material
Product name: Gate Valve		Classe: 300LB
Designer: CDV INDUSTRIAL		Type: Z40H
Date: MAR/2025		Drawing: Fig 84